

Piranha

Pond One[®]

Models: 800/1500/2500/3500/5000/8000/10000



Instruction Manual

Important Safeguards

WARNING: To guard against injury, basic safety precautions should be observed, including the following:

WARNING: This unit is not designed to be used out of water. It must only be operated whilst submerged in water, unless installed as an inline pump on a correctly setup filtration system.

This appliance is not intended for use by persons (including children) with reduced physical, sensory or mental capabilities, or lack of experience and knowledge unless they are supervised adequately by a responsible person to ensure that they can use the appliance safely. Children should be supervised to ensure that they do not play with the appliance.

Read and follow all safety instructions before using this appliance. There maybe additional electrical safety instructions relevant to your country on page 5.

WARNING: To avoid possible electric shocks, special care should be taken where water and electricity are combined, for each of the following situations do not attempt repairs yourself. Return the appliance to an authorised dealer for servicing.

If you have any doubts about the electrical installation you should consult a qualified electrician. Please observe local laws and regulations regarding the installation of ponds and pond equipment. Always abide by these regulations. If in any doubt please consult your local government planning department or authority.

This appliances is intended for outdoor garden pond use only, don't use the appliances for any other purpose. The appliances must be installed with a residual earth leakage circuit breaker. (RCCB OR RCCD of 30mA in the supply line to the appliance)

If the appliance shows any sign of abnormal water leakage or malfunction, immediately disconnect it from the power source. Do not attempt repairs yourself.

Carefully examine the appliance after installation. It should not be plugged in or connected to the mains power supply when there is water present on parts which are not supposed to be wet.

Do not operate the appliance if it has a damaged power supply cord or plug, or it is malfunctioning, or has been dropped or damaged in any manner. If the plug or socket does get wet, do not unplug or disconnect the appliance from the socket.

Disconnect the fuse or circuit breaker that supplies the power to the appliance, then unplug and examine for presence of water in the socket.

To avoid the possibility of the appliance plug or mains connection socket getting wet, position the switch box or outdoor weather proof socket at least 2 metres from the pond side. It should also be raised above possible flooding zones.

Always disconnect the appliance from the electrical outlet when not in use, before putting on or taking off parts, before any type of maintenance or cleaning. Never yank or use the power cord to pull it from the outlet or from the pond. Only carry by the handle.

NEVER CARRY THE PUMP BY THE ELECTRIC SUPPLY CABLE THIS WILL DAMAGE THE PUMP AND MAKE IT UNSAFE.

Do not use the appliance for reasons other than the intended use. The use of attachments that are not sold or recommended by the appliance manufacturer may cause the product to be unsafe. We strongly recommend against it.

Do not install or store the appliance where it will be exposed to weather or temperatures below freezing.

Read and observe all the important notices on the appliance type plate.

Maximum main power supply 10 meters.

The appliance comes with 10 meters of mains power cable. It should not be extended.

The external flexible cable or cord of this pump cannot be replaced. If the cord is damaged the pump should be scrapped.

Appliance shall only be used with rated voltage and frequency. 220 - 240V~50HZ

For Guarantee Conditions, please refer to the Guarantee form on page 12 of this instruction manual.



Warning: This appliance must not be disposed of together with domestic waste. It must be disposed of at an authorised centre set up for the recycling of electrical and electronic appliances. By collecting and recycling waste, you help save our natural resources. Please Make sure this product is disposed of in an environmental friendly and safe way.

Before First Use / Preparation

Read and follow all the instructions, even if you feel you are familiar with the product. Find a place to keep the instructions handy for future reference. Your attention is drawn particularly to the sections concerning “**IMPORTANT SAFEGUARDS**” and “**POND ONE GUARANTEE**”. Please ensure you retain your original purchase receipt in the event that guarantee service is required.

Carefully unpack the pump making sure you keep all the packing material until all the parts of the product have been found and the product has been assembled.

Replacement Parts

Use Pond One Genuine Spare Parts Only. See your local Pond One Dealer and look for the number listed below for the spare part you require. Alternatively you will find these numbers on the silver label located on the product.

Piranha 800	216I
Piranha 1500	217I
Piranha 2500	218I
Piranha 3500	219I
Piranha 5000	220I
Piranha 8000	221I
Piranha 10000	222I

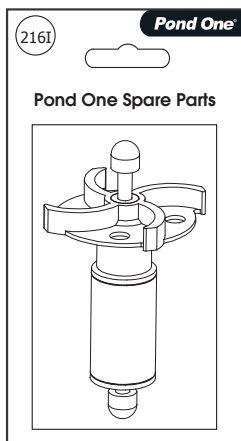

This product is shipped to you in a factory sealed carton. Should the product malfunction in any way or if the unit is damaged and requires replacement, contact the retailer where the product was purchased for inspection.

The plug supplied with this product is a sealed plug and we do not recommend removing or changing it.

The external flexible cable or cord of this pump cannot be replaced. If the cord is damaged the pump should be scrapped.

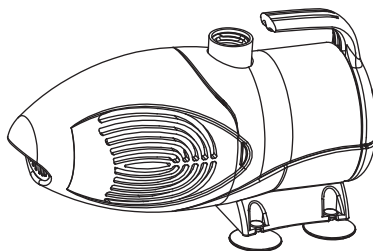

Precision Manufactured in the P.R.C.
Designed in Australia by Aqua One
Distributed in Australia by:
Kong's (Aust.) Pty. Limited
48 Williamson Rd. Ingleburn
2565 NSW Australia

Distributed in New Zealand by:
Kong's (NZ) Limited
52 Glenlyon Avenue. Greerton
Tauranga New Zealand

Distributed in Hong Kong by:
Kong's Aquarium Supplies Co., Ltd
No 31, 3/F Thriving Industrial Centre
26-38 Sha Tsui Road, Tsuen Wan
Hong Kong

Distributed in the UK by:
Kong's (UK) Limited,
C/O Aqua Pacific UK Ltd.
PO Box 268
Romsey Hampshire
SO51 0WW
United Kingdom



Pond One®

www.pondone.com.au

Pond One and Kong's are registered trademarks or trademarks.



220 - 240V ~ 50HZ



Know Your Pump

- 1. Strainer Cover
- 2. Prefilter Sponge
- 3. Impeller Cover
- 4. Impeller
- 5. Motor

- 6. Shaft
- 7. Aquadisc
- 8. Rubber End Caps

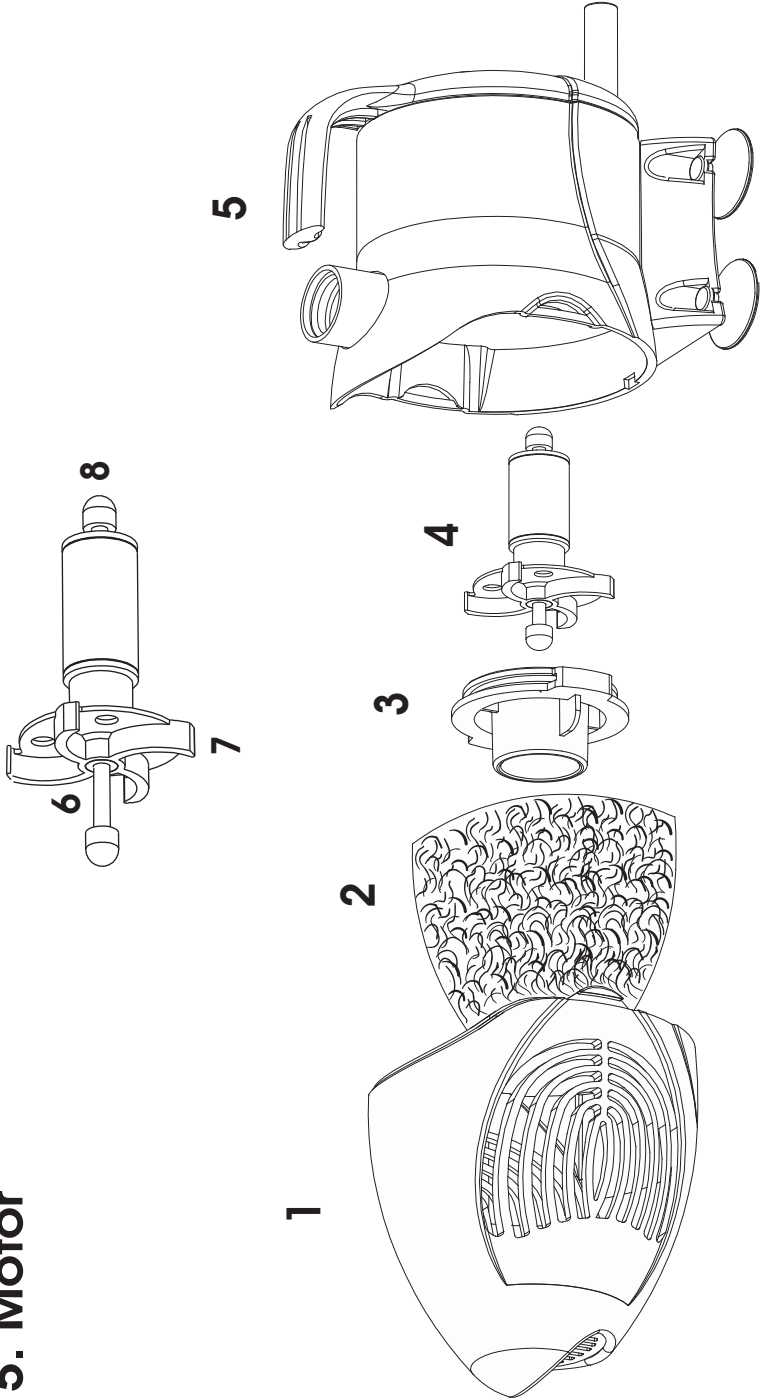

Connecting your appliance to the mains electricity supply

- Country specific instructions.

Always check local government regulations prior to installing your Pond One product

United Kingdom

According to government guidelines pond equipment intended for permanent installation outside must be supplied without a fitted plug.

These appliances are intended for connection to or hard wiring to the mains supply by means other than a conventional plug and socket

This means either a suitable specialist weather proof outdoor socket or a hard wired socket indoors must be used. All cables from the appliance to the socket should be led through a suitable approved conduit and buried in the ground or raised above the ground so clearly visible. Thus avoiding accidental damage from actions like digging of the ground or mowing of the grass.

A approved earth leakage circuit breaker (RCCB) or otherwise known as an Residual circuit current device (RCCD) must be fitted in the supply line.

The appliance should be connected to the mains supply using the following colour coding. Refer to Diagram 1

Red or brown wire - to the live connection 'L'

Blue or black wire - to the Neutral connection 'N'

Green with Yellow stripe wire - to the Earth connection 'E'

IF YOU ARE IN ANY DOUBT ABOUT INSTALLING YOUR APPLIANCE YOU SHOULD CONSULT A QUALIFIED ELECTRICIAN.

Australia, New Zealand and Hong Kong

In Australia, New Zealand and Hong Kong all products are supplied with fitted plugs. This plug should **NOT** be tampered with in any way or removed. Removal or tampering with the plug invalidates our guarantee offered with this product.

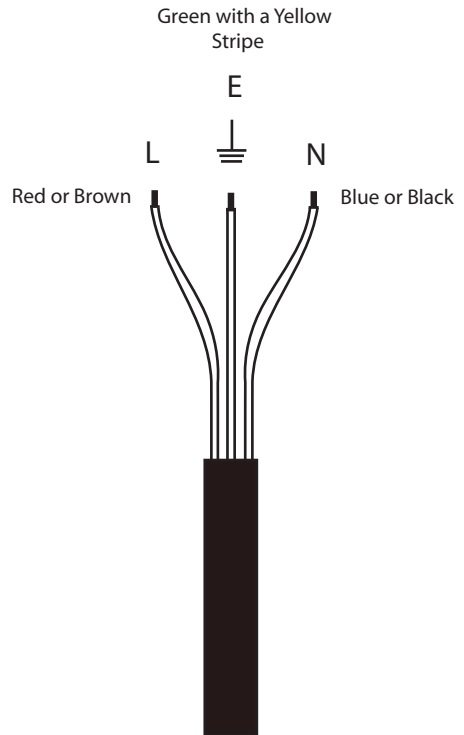

Diagram 1

Pump Installation

Installation

Please refer to the following page for suggested installation of the fountain head fittings which are supplied with your pump.

Your Piranha pump is supplied with a Stepped Hose Tail which can be attached to the Flow Control Adjuster and used to run a waterfall or second feature. Simply remove the Blanked Plug and attach the Stepped Hose Tail, then press your selected hose onto the Stepped Hose Tail. It can take a number of different sized hoses. You should always use the largest hose size possible to minimise flow resistance in the pipes through frictional loss. We recommend using 1/2" (12mm) or 3/4" (20mm) hose. **PLEASE ENSURE YOU CUT OFF** the smaller hose sizes from your stepped hose tail that are not being used. (A hack saw is recommended for this) Failure to do this will result in significant flow loss.

PLEASE NOTE: The Piranha is primarily a fountain pump. It is only capable of running a small second feature. Consult your pond specialist for further advise.

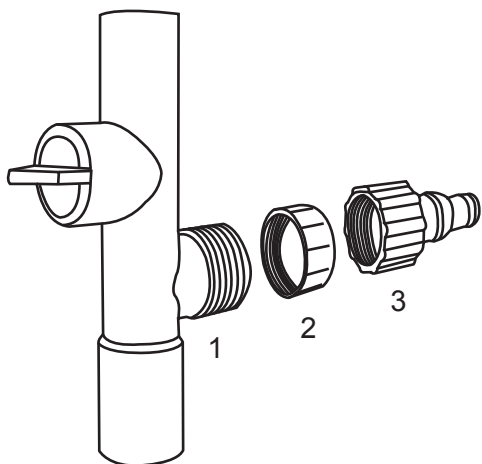

1. Flow Control Adjuster
2. Blanking Plug
3. Stepped Hose Tail

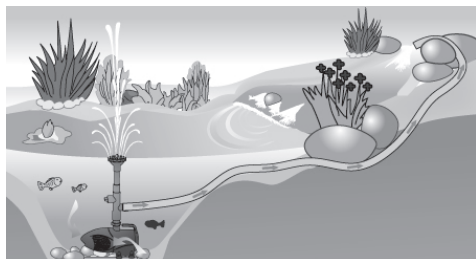

All pumps on the market are affected by loss of flow in the pipe fitted to them. Hence, hose length should be kept to a minimum and size as large as possible to minimise the flow reduction.

Before immerse your pump in the pond make sure the end of the cable (Plug end) never falls into the water.

The pump should be immersed in the pond and left for a few minutes before switching on.

Positioning of your pump

Please observe the maximum immersion depth on the pump model plate! If you wish to raise your pump off of the bottom of the pond this is OK. The minimum water depth above the pump should be 30cm.

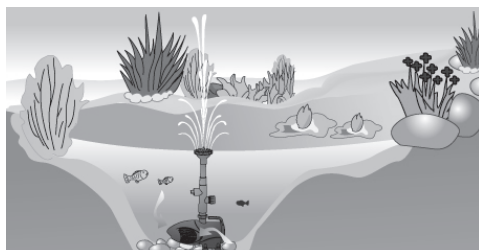

The pump should ideally be positioned at the opposite end of the pond from where the water returns to the pond. This helps the circulation of water. However, it is always a good idea to occasionally move the pump around larger ponds to reduce dead spots. (static wate)

Piranha 800

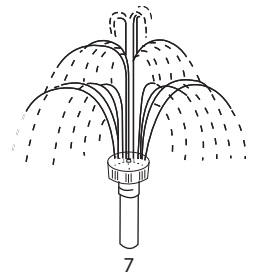
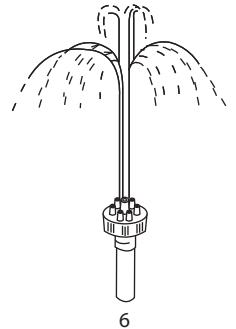
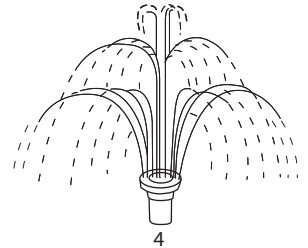
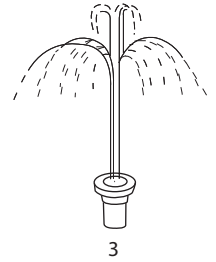
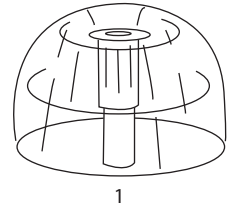
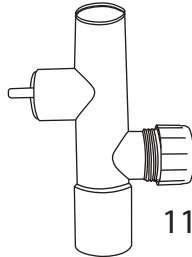
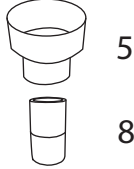
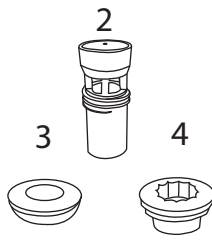
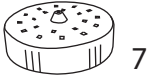
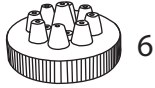
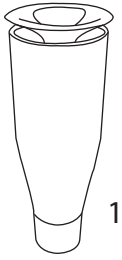

1. Mushroom Outlet
2. Center Insert
3. Two Tiered Fine Outlet
4. Three Tiered Fine Outlet
5. Adaptation Plates
6. Two Tiered Course Outlet
7. Three Tiered Medium Outlet
8. Sleeve
9. Extension Tubes
10. Reducer
11. Flow Control Adaptor
12. Screw in Fitting
13. Pump

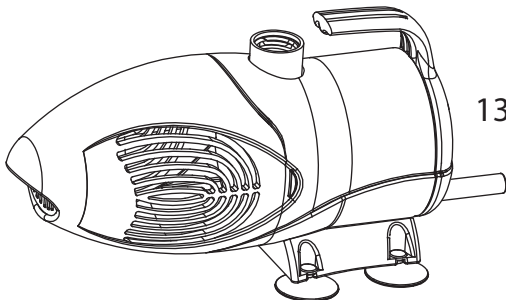

To change between the Two and Three Tiered Fine Outlets hold the Adaptation Plate and turn the Center Insert anti-clockwise, remove it and replace the outer disk.

Piranha 1500/2500/3500/5000

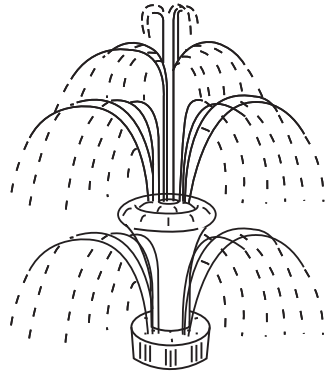
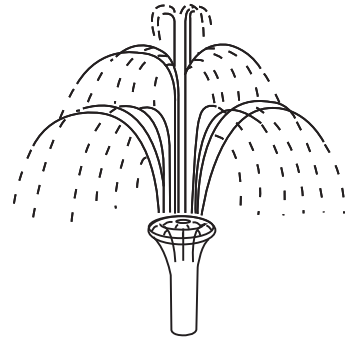
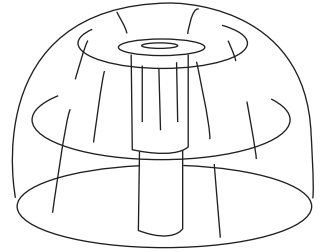
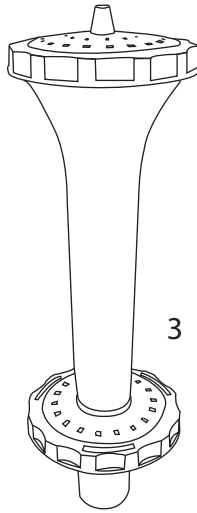
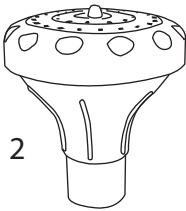
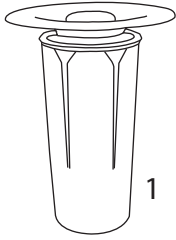

1. Mushroom Outlet
2. Two Tiered Fountain Head
3. Three Tiered Fountain Head
4. Extension Tube
5. Sleeve
6. Flow Control Adaptor
7. Screw in Fitting
8. Pump

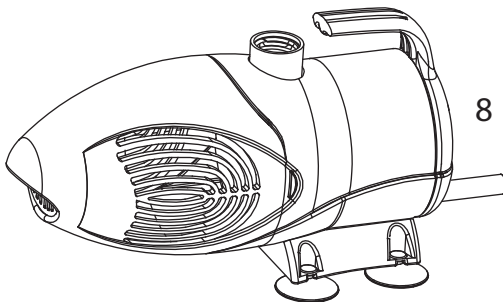
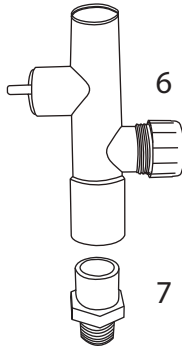

Piranha 8000/10000

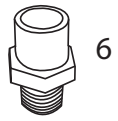
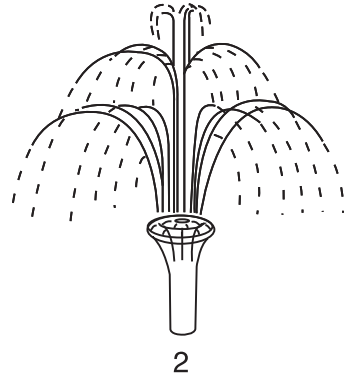
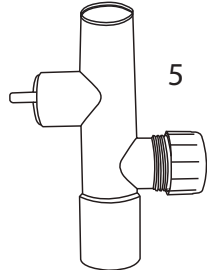
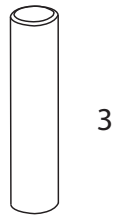
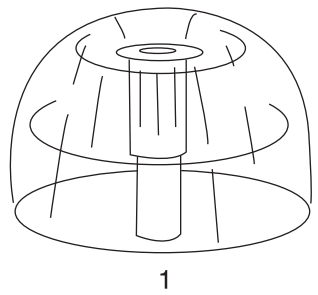
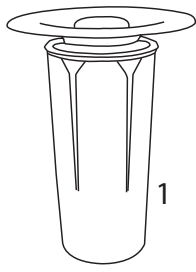
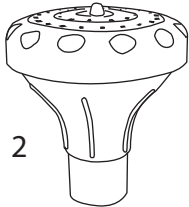

- 1. Mushroom Outlet
- 2. Two Tiered Fountain Head
- 3. Three Tiered Fountain Head
- 4. Extension Tube
- 5. Sleeve
- 6. Flow Control Adaptor
- 7. Screw in Fitting
- 8. Pump

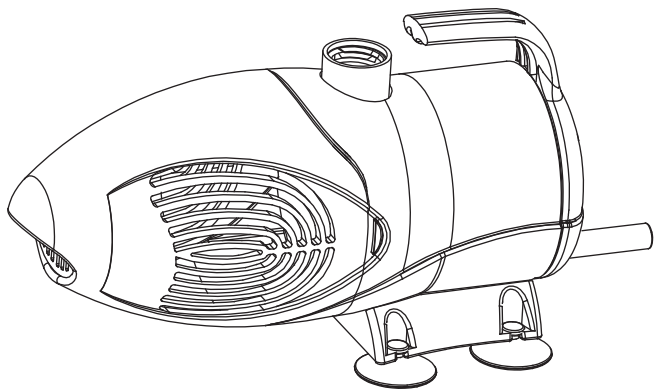

Accessing The Impeller

1. Turn the pump off at the main power supply and remove it from the water.

2. Remove the Strainer Cover from the front of the pump. To do this gently squeeze the sides of the Strainer Cover together and pull it away from the Motor.

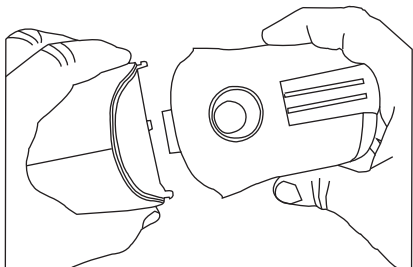

Fig 1

3. Now you must remove the Impeller Cover. Hold the pump steady with one hand and turn the impeller cover anti-clock wise to unlock it and remove.

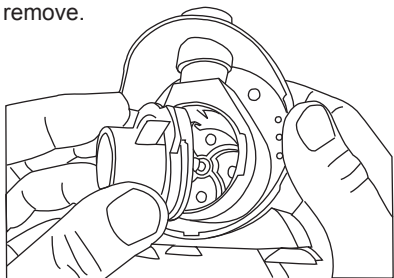

Fig 2

4. Sometimes the impeller will come out when the Impeller Cap is removed. If not gently remove the Impeller using your fingers.

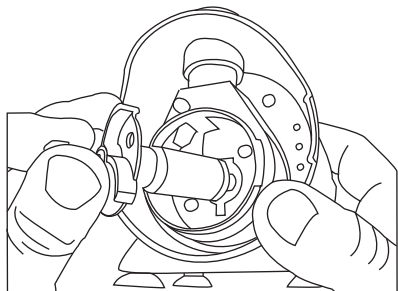

Fig 3

5. The Impeller consists of two Rubber End Caps, a Stainless Steel Shaft and the Aquadisc. Be careful not to loose the Rubber End Caps when removing the Impeller from the Impeller Well.

Rubber End Caps

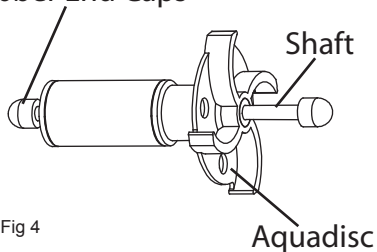

Fig 4

6. Using a double ended pipe brush, clean the Impeller unit and the Impeller Well. **DO NOT** use any abrasive scouring pads or implements.

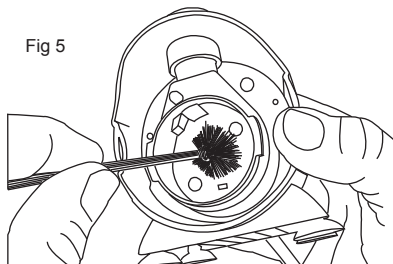

Fig 5

7. We recommend pouring some clean fresh water into the impeller chamber before reassembly. Please ensure the Impeller Well is free from debris before reassembling the pump, failure to do so could damage your pump.

8. Reinsert the Impeller Unit and replace the Impeller Cap.

9. Prior to reassembly clean your sponge thoroughly. Use a high pressure hose. Remember that the cleaner your sponge is the better the pump will perform.

10. Reassemble the pump and return it to the pond.

11. Before plugging the pump back into the main power supply ensure the plug end is **NOT** wet.

Trouble Shooting

WARNING: Disconnect electrical supply before commencing any work on the pump.

1. THE PUMP KEEPS SWITCHING OFF.

All pumps are fitted with thermal overload protectors to protect the pump against overheating. If this is activated it is normally due to flow through the pump being restricted. When the pump cools down it will automatically restart.

Clean the pump according to the cleaning instructions ensuring all debris has been removed from the strainer and prefilter sponge. Ensure water can enter the pump without restriction.

Check that the impeller rotates freely. If not, clean the impeller as directed. (See Accessing the Impeller)

Check all pipes or hoses from the pump to waterfall, UVC or filter are clear. As restricted flow will have the same effect, reduce pump performance and cause overheating.

2. THE FLOW HAS REDUCED.

Check all pipes for kinks. Hoses buried under ground may also be crushed by moving soil.

Clean pump according to cleaning and maintenance instructions.

Calcium/Limescale.

Pump output can also be reduced by the effects of limestone or calcium build up especially in 'hard water' areas. Pumps should therefore be descaled regularly to maximize life expectancy.

Procedure: Disconnect power supply and remove pump from pond, remove pump from strainer (see Accessing the Impeller) remove the complete impeller. The whole motor and impeller should be immersed in a suitable descaling agent like that used for kettles or a specialist pump descaler. Once the calcium has been removed thoroughly wash all parts in freshwater before reassembling to remove any traces of the descaling agent.

3. THE PUMP WILL NOT SWITCH ON AGAIN.

Verify the pump is connected to the mains supply. Check all fuses, earth leakage circuit breakers and connections. If this all seems OK try an alternative power source.

4. THERE IS POWER TO THE PUMP BUT THE IMPELLER DOES NOT TURN.

Check the impeller moves freely and no small pieces of grit have got caught behind the impeller. (See Accessing The Impeller)

DO NOT USE YOUR FINGERS TO MOVE THE IMPELLER.

If you are not able to solve any of the above problems with your pump, please contact your pond specialists for further advice and servicing.

Model Specifications

Model: Piranha 800
Max Output l/hr: 800
Max Lift / Head: 1m
Power Consumption: 12W
Power Requirements: 220 ~ 240V
Suitable: Freshwater

Model: Sting Ray 1500
Max Output l/hr: 1560
Max Lift / Head: 1.4m
Power Consumption: 14W
Power Requirements: 220 ~ 240V
Suitable: Freshwater

Model: Piranha 2500
Max Output l/hr: 2500
Max Lift / Head: 2.5m
Power Consumption: 55W
Power Requirements: 220 ~ 240V
Suitable: Freshwater

Model: Sting Ray 3500
Max Output l/hr: 3560
Max Lift / Head: 3.2m
Power Consumption: 57W
Power Requirements: 220 ~ 240V
Suitable: Freshwater

Model: Sting Ray 5000
Max Output l/hr: 5000
Max Lift / Head: 3.8m
Power Consumption: 86W
Power Requirements: 220 ~ 240V
Suitable: Freshwater

Model: Piranha 8000
Max Output l/hr: 8000
Max Lift / Head: 4.8m
Power Consumption: 162W
Power Requirements: 220 ~ 240V
Suitable: Freshwater

Model: Sting Ray 10000
Max Output l/hr: 10000
Max Lift / Head: 5m
Power Consumption: 283W
Power Requirements: 220 ~ 240V
Suitable: Freshwater

Pond One - Guarantee 2 + 1 Year

The additional 1 Year Extended Guarantee applies when you REGISTER with Pond One. See enclosed for details.

ATTENTION!

PLEASE RETAIN YOUR PROOF OF PURCHASE AND GUARANTEE

Congratulations on your purchase of a quality Pond One product. This product will last you many years under normal usage.

About this Guarantee

The Manufacturer or Distributor, of Pond One goods, is collectively known herein as "Pond One". Please refer to contact details for Pond One below or on the applicable Pond One website. Any product that is covered by its own Guarantee (as enclosed with the product) is subject to the conditions of that Guarantee.

The benefits given to the purchaser, under Guarantee, are in addition to all other statutory rights and remedies which the purchaser has in respect of goods under legislation in the applicable country of purchase. This Guarantee shall not affect any such rights and should be read subject to such legislation.

1.0. Terms and Conditions of Guarantee.

- 1.1. Pond One warrants to the purchaser, for 2 Years from date of original purchase, to repair or replace goods where fault is found due to defective materials or faulty workmanship and where goods do not operate in accordance with the instructions.
- 1.2. All claims for repair or replacement must be made at place of purchase.
- 1.3. The original and dated Proof of Purchase (receipt) must be supplied with all goods claims. Please also provide this Guarantee where possible.
- 1.4. All goods subject to claim under Guarantee should be prepared for transportation in the original packaging or other comparable packaging which offers the same degree of protection.
- 1.5. Where goods are repaired or replaced under Guarantee, these goods are Guaranteed for the remainder of either the original Guarantee or Extended Guarantee period.
- 1.6. Where claims on inspection reveal goods are in normal working order, Pond One will request reimbursement of all reasonable costs incurred.

2.0. Other Terms and Conditions – Extended Guarantee

- 2.1. The Extended Guarantee period is for an additional 1 Year and commences on expiration of the standard guarantee period.
- 2.2. Application for Extended Guarantee is FREE of any registration cost to the purchaser on completion of the Extended Guarantee questionnaire which may be found with the Pond One goods purchased or on the applicable Pond One website. (See below)
- 2.3. Upon receipt and acceptance of the questionnaire, Pond One will forward a Certificate of Extended Guarantee to the purchaser.
- 2.4. For more information on how we collect, hold, use and disclose personal information provided to us, please refer to our Privacy Statement on the Pond One websites or write to our Privacy Officer, in your country of purchase.
- 2.5. Where Pond One determines goods are being used in a manner contrary to the instructions, specifications or this Guarantee, Pond One reserves the right to terminate Extended Guarantee for such goods and will provide written notice to the purchaser.

3.0. Exclusions and Limitations

Where permitted by local law, the following exclusions and limitations apply in regard to the Guarantee:

- 3.1. Goods claims where fault is due to, but not limited by a) misuse b) neglect c) abuse d) fire or flood e) normal wear and tear f) accidental breakage g) Acts of God h) mains voltage fluctuation or supply problems i) connection to any voltage other than what is stated on the rating plate j) modification or tampering to electrical cord or plug, k) vermin, insects or foreign object l) liquid spillage or submersion of goods where goods are not designed to sustain such use or duress.
- 3.2. Where inspections reveal goods are in normal working order including where noise or vibration is consistent with normal goods operation.
- 3.3. Attempted repairs or modifications by unauthorised persons, including but not limited to modifications to the electrical lead or plug.
- 3.4. Where the goods factory rating plate has been removed, altered, damaged or is rendered illegible.
- 3.5. Where goods are not installed, operated or maintained in accordance with Pond One's goods instructions, specifications or this Guarantee.
- 3.6. Replacement or repair of worn consumables or replacement of lost goods, parts or components.
- 3.7. Costs associated with goods transportation, removal, installation, postage or cost of insurance.
- 3.8. Any damage incurred whilst installing, transporting or moving the goods.
- 3.9. Subject to certain local statutory rights and obligations to the contrary, and this guarantee shall not affect those rights or obligations, where, to the full extent permitted by law:

1. all express and implied warranties and conditions under statute or general law, are expressly excluded and Pond One, where permitted, will limit liability as follows and at Pond One's option to: in regard to goods either a) the replacement of goods or supply of equivalent goods b) the repair of goods or the cost of replacing the goods or of acquiring equivalent goods OR in regard to services either c) the re-supply of services d) the cost to re-supply services.

2. Pond One will not be liable for any loss or damage, including consequential loss or damage either directly or indirectly, or for any incidental expenses, of any kind, and in any way whatsoever.

(1) Consumables include items such as Impellers, rotors, o-rings, fountain headsets and other plastic fittings.

Pond One may be contacted in:

Australia
Kong's (Aust.) Pty. Limited
PO Box 863, Ingleburn
1890 NSW Australia
www.pondone.co.uk

Hong Kong
Kong's Aquarium Supplies Co., Ltd
No 31, 3/F Thriving Industrial Centre
26-38 Sha Tsui Road, Tsuen Wan
Hong Kong
www.pondone.co.hk

New Zealand
Kong's (NZ) Limited
PO Box 15 - 183, Tauranga
3015 New Zealand
www.pondone.co.nz

United Kingdom
Kong's (UK) Limited
C/O Aqua Pacific UK Ltd
PO Box 268
Romsey Hampshire, SO51 0WW
United Kingdom
www.pondone.co.uk